

# WE ARE PIM AND ALEX OF CO&CO



Two brothers who are crazy about cycling. We come from the Netherlands, where almost everyone has one or two bikes. We are enthusiastic cyclists, and we have been importing loads of fun toys, especially ones with wheels – including balance bikes – for more than 10 years by now. In 2014, we started developing our own balance bike, applying all of our knowledge as toy sellers and enthusiastic cyclists during the process. We had great fun designing the perfect balance bike: durable, strong, and, to top it all, darned good-looking to boot! The result: the Trybike, which is exactly the kind of bike we would have loved to have had as kids!

ENJOY YOUR TRYBIKE AND LET US KNOW WHAT YOU THINK



CO&CO BV, KONING LODEWIJKLAAN 40C, 7314 GG APELDOORN, THE NETHERLANDS  
+3155 522 28 63, WWW.COANDCO.NL, INFO@COANDCO.NL

## ⚠ WARNING!

- Adult assembly only!
- Read all assembly instructions, warnings and maintenance instructions before you start.
- If you do not read/follow these instructions carefully, the Trybike could be assembled incorrectly and/or it may get damaged, which might lead to serious injury during use.
- Remove all bags, packaging materials and protective materials before allowing a child to use the bike.
- The Trybike is not suitable for children weighing more than 35 kg/77lbs
- Make sure your child wears proper protective gear when riding the Trybike. Use an approved safety helmet and closed-toe shoes. It is also a good idea to wear gloves as well as elbow and kneepads, long trousers and outer garments with long sleeves.
- A child should always be under adult supervision when riding the Trybike.
- Always let your child ride in front of you, not behind you.
- Regularly check that all parts are secure and undamaged, paying particular attention to the handlebars, wheels and seat. Make sure you perform a thorough check-up 14 days after assembly.
- If the Trybike is in some way damaged, do not use it again until it has been repaired by an authorised Trybike dealer.
- No more than ONE child on the Trybike at a time!
- Before your child gets on the bike, explain how the Trybike should be stopped by using your feet.
- Never allow children to use the Trybike on public roads, in areas where there are cars, on slopes, on stairs, on or near bridges or near water (e.g. swimming pools, rivers, ponds, ditches, canals) or in other places that could be dangerous.
- Do not use Trybike in the dark or at dusk.
- Do not use the Trybike on the beach, near salt water or on roads with road salt. Should the Trybike come into contact with salt, rinse the Trybike with plenty of water.
- Keep these instructions and safety precautions in a safe place for future reference.
- Co&Co cannot be held liable for any injuries or accidents caused by the use of a Trybike. The buyer accepts the risks involved in the use of the Trybike.



## ASSEMBLING THE TRYBIKE

We have already partially assembled the Trybike. We would love to put the entire bike together for you beforehand, but then we would have to ship it in a large box. This would make transportation very expensive, it would be bad for the environment and no fun for the poor postman.

### WHAT IS IN THE BOX?

- Frame with front forks attached to it.
- 2 wheels
- 2 short wheel axles with 2 long nylon black bushings, rings and 2 cap nuts
- Seat with seat pen
- Handlebar with stem
- 2 handlebar grips
- Sticker set
- Tool set (1 x Allen key and 2 x open end wrench)
- Trybike user instructions



### FITTING THE FRONT AND REAR WHEELS INTO THE FORKS

The front and rear wheels are identical and need to be mounted in the same way. Insert the black nylon bushings into the wheel, with the narrow part of the bushing fitting into the bearing of the wheel. Position the wheel with the black nylon bushings between the front forks so that the holes of the front forks are exactly aligned with the holes of the bushings. Insert the axle through the front forks, the bushings and through the wheel. Before you push the axle all the way through, put rings and a nut on one side of the axle, giving it a few turns. Push the axle entirely through the hole and fit rings and a nut on the other side, again giving it a few turns. Once fitted, tighten the nuts on both sides simultaneously and check whether the wheel rotates smoothly.



### UNIQUE ADJUSTABLE WHEEL POSITION, HEIGHT AND LENGTH

The Trybike has a unique system for adjusting the bike to children's skills and sizes. For each stage of your child's development it offers a perfect wheel position.



### FRONT WHEEL HEIGHT

The front fork has 2 options for positioning the wheel. Hole 1 makes the bike lower. If your child is small or starting with the tricycle option, this is the best position. If your child is taller, the wheel can be in hole 2. This will put the Trybike in the highest position.

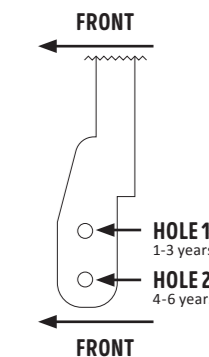

### HEIGHT AND POSITION REAR WHEEL

The rear fork has 9 options for positioning the rear wheel. This feature allows you to shorten, extend, lower or raise the wheelbase. Hole 1 puts the bike in the lowest position, hole 5 in the highest position, hole 3 provides the longest wheelbase and is ideal for the tricycle position and hole 7 provides the shortest wheelbase, making the Trybike even more manoeuvrable.

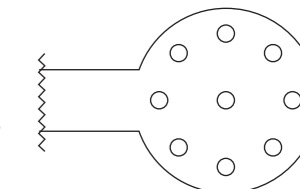

For use as a tricycle:

- Starter: Front, use hole 1. Rear, use hole 1. (the lowest position)
- Advanced: Front, use hole 1. Rear, use hole 3. (this gives more room for the feet relative to the long axle)

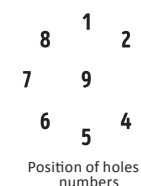

Position of holes + numbers

For use as a two-wheeler:

- Starter: Front, use hole 1. Rear, use hole 1 or 9. (depending on child size)
- Advanced: Front, use hole 1. Rear, use hole 9. (regular distance between wheels)
- Very skilful: Front, use hole 1. Rear, use hole 7. (shorter distance between wheels and as a result more manoeuvrable)
- Advanced and large: Front, use hole 2. Rear, use hole 5. (extra high position)

## ASSEMBLY OF THE LONG REAR AXLE AND THE TWO REAR WHEELS

(TRIKE KITS SOLD SEPARATELY)

Remove the parts of the long axle, please note: one nut is sealed and only one nut can be unscrewed. Insert the short aluminium pipe in between the rear forks. Insert the short black bushings into the wheels, with the narrow part of the bushings into the wheel bearings. Then slide one wheel with the bushings over the rear axle up to the sealed nut at the end of the axle. Push the long aluminium pipe over the axle up to the wheel and slide the axle, from the left side of the rider, into the holes of the rear forks and through the aluminium pipe. Important, keep the sealed nut on the left side of the rider. This way the nut on the other side won't turn loose when the Trybike is ridden. Slide the remaining long aluminium pipe and the wheel with the bushings onto the right side of the rear axle and fasten the wheel with the nut. Finally, tighten the nut properly (not too tight but also not too loose) and check that the wheels rotate smoothly and the nuts don't turn. Put the short axle in the supplied bag and store it, so you can convert the tricycle to a bicycle in the future.

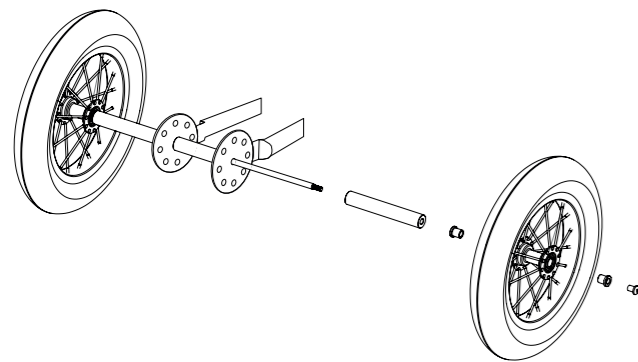

## HANDLEBAR HEIGHT FOR STARTING RIDERS

For a starting rider, the best handlebar height is at more or less halfway the torso or a little higher when your child is sitting on the seat and the feet are flat on the ground. Your child must easily be able to hold the handlebar with slightly bent arms. Most important is that your child has a good overall view, like you have on a city bike for adults. The handlebar should not be too low because your child will be too far ahead and will then not have a good overall view.

## HANDLEBAR HEIGHT FOR EXPERIENCED RIDERS

Children who have used the Trybike for a while and those who are very skilled and a bit adventurous with the bike can have their handlebar installed lower than the seat. Actually, this is similar to a mountain bike or race bike. In reality, it means that you will have to adjust the seat height regularly (upwards) but the handlebar rarely or not.



## FITTING THE HANDLEBAR INTO THE FRONT FORK

Remove the black plastic protective cover from the handlebar bottom. Slide the handlebar into the front fork, making sure that the handlebar and the slanted clamp bolt form a unity (see photo). Please note: Make sure the flat bottom of the front fork points forward, with the wheel axle in the front, see drawing. Position the handlebar to the correct height for your child and use the socket bolt at the top of the handlebar to tighten it.

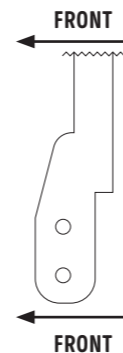

## ADJUSTING THE SEAT

Unlock the seat clamp quick release by pulling the lever towards you (see photo). Determine the seat height and push back the lever of the quick release. If the seat pen is still a bit loose when the quick release is closed, adjust it as follows: unlock the quick release, turn the round "nut" opposite the lever clockwise and close the quick release. If the seat pen is still loose, turn the round "nut" even tighter.

## CORRECT SEAT HEIGHT

The seat will be at the correct height when your child can just reach the floor with the heels. If the seat is too low in tricycle mode, the heels tend to touch the back axle, and in bicycle mode, the child's feet will end up dragging slightly. So, ensure the seat is not too low.

## STICKERS

The Trybike comes with a set of stickers. You can choose which stickers you like best and stick those on the Trybike. Place the small oval Trybike logo sticker at the front of the bike just above the front fork. The Trybike name stickers go on the sides of the frame.

## MAINTENANCE

Regularly check that all parts are secure and undamaged, paying particular attention to the handlebars, wheels and seat. Make sure you perform a thorough check-up 14 days after assembly.

### TYRES

We recommend that you inflate all the tyres to approximately 30 PSI to 35 PSI (2.0 to 2.4 bar). You should still be able to push in the tyre a little with your thumb. Do not overinflate the tyres. **Do not exceed 35 PSI, because the tyre may burst!** Regularly check the tyres and wheels for damage and correct tyre pressure.

### CLEANING

To clean the Trybike, use car wash detergents, lukewarm water and a soft cloth.

### LUBRICATION

Lubricate the axles, the ball head and the bearings of the wheels lightly with standard bicycle oil.

### STORAGE

Store the Trybike in a warm, dry and well-ventilated area at room temperature. Do not keep it outside or in a cold damp storage area and keep out of extreme temperatures. Use the supplied bag for storing the long axle or short axle if not used.

## WARRANTY

Designing our bikes took a lot of time, and each Trybike has been manufactured with great care and attention. Every Trybike is checked separately, but production errors may still slip through. That's why the Trybike comes with a 2-year warranty period from date of purchase against any manufacturing defects. We will repair or replace the Trybike free of charge during this period if you should encounter any manufacturing defects. If you have any problems with your Trybike, please contact the (online) store where you purchased your Trybike.

This warranty is valid only for the original purchaser who bought the product new from an authorised dealer, so make sure you keep a copy of your receipt.

Your warranty will be likely to become void if you have modified the Trybike in any way, if the problem is due to normal wear and tear, if you bought the Trybike in a used condition or if the Trybike has not been correctly assembled, used and/or maintained.

Please contact us if you have any problem with your Trybike, because we can always help you, even if your warranty is no longer valid. We designed the Trybike so that it can always be fixed. All components are available and can be ordered separately. We will do everything we can to ensure that children may enjoy the Trybike for as long as possible. Rights may vary by country.

This product complies with the following toy safety requirements: AS/NZS ISO 8124, EN 71 and **CE**



## USER INSTRUCTIONS

TRYBIKE  
STEEL



## HAVE FUN WITH THE TRYBIKE!

Thank you for buying an original Trybike! We wish your child lots of fun and adventure with the new bike.

The Trybike can be used by children from around two years old. If you purchased the Trike Kit option, the Trybike can be used as a tricycle from the age of about 15 months.

The Trybike is perhaps the best and most enjoyable toy you can give a child. While

using the Trybike children will develop their walking, riding and balancing skills. These are skills they need in later life, like to ride a pedal bike.

With the unique footrest children learn to balance even better and, consequently, learning to ride a pedal bike without training wheels will be peanuts.

Have fun!